

# Installation Guidelines: One Piece & Two Piece Molding Systems



**WARNING: FAILURE TO FOLLOW THESE GUIDELINES  
WILL VOID THE STANDARD WARRANTY.**



**BE SURE TO READ, UNDERSTAND AND FOLLOW ALL GUIDELINES.** Manufacturer guidelines may vary depending upon specific application and project conditions. The manufacturer should be contacted with questions regarding conditions which vary from the guidelines set forth. Standard carpentry knowledge is required and good construction practice for health, safety and welfare must be followed when installing SinoCore®.

## TABLE OF CONTENTS

Pre-Installation Guidelines..... 2  
 General Work Guidelines..... 5  
 Work Sequence: One Piece Moldings..... 9  
 Work Sequence: Two Piece Moldings.....13  
 Trim Moldings.....17  
 Recommended Tooling & Equipment.....19  
 Installation Accessories.....19

## MAIN STEPS OF THE INSTALLATION PROCESS

**FIRST: UNDERSTAND THE SYSTEM**

Understanding the panel system and determining which attachment option has been specified is imperative for completing a proper installation.

<b>NOTE:</b>
<p><b>To request a complete Product Manual (which includes recommended SECTION and MOLDING INTERSECTION details), contact the manufacturer.</b></p>

**SECOND: PRE-PLAN THE INSTALLATION**

After receiving and properly storing the material, planning the work schedule, grid layout, and material usage should be performed so that the sequence can proceed without significant delays and/or problems.

**THIRD: READ THE GENERAL GUIDELINES**

The general guidelines (i.e. fabrication, sealing, etc.) provide a groundwork for all types installations. Thoroughly read and understand these guidelines before beginning the work sequence.

**FOURTH: COMPLETE THE WORK SEQUENCE**

After reading the instructions set forth in the general guidelines, continue to the appropriate work sequence and complete the installation.

## KEY POINTS FOR A SUCCESSFUL INSTALLATION

• **SAFETY FIRST**

Proper protection (i.e. gloves, safety glasses) should be worn at all times to prevent injury from sharp edges and/or metal shavings.

• **PROTECT MATERIAL**

When installation is not in progress, all panel and accessory units must be kept under protective cover and completely dry.

• **ENSURE PROPER FIT**

Proper fit is very important to the appearance of the system. Allowance for expansion is needed, as well as notching and/or mitering of trim.

• **LIBERALLY APPLY SEALANT**

ALL joints must be sealed against moisture intrusion or the warranty will VOID. If done correctly, excess sealant will squeeze from the joints (to be removed later in the sequence).

• **REMOVE PROTECTIVE FILM**

Upon completion, the protective film must be removed from the painted surface. Failure to do so promptly may cause difficulty in removal and possibly leave an adhesive residue.

## TECHNICAL ASSISTANCE

Citadel Architectural Products, Inc.  
 3131-A North Franklin Road  
 Indianapolis, Indiana 46226  
 phone: (317) 894-9400  
           (800) 446-8828  
 fax: (317) 894-6333  
       (800) 247-2635  
 www.citadelap.com  
 info@citadelap.com

©2003 Citadel Architectural Products, Inc. An ISO 9001:2000 Registered Company.  
 SinoCore® is a registered trademark of Citadel Architectural Products, Inc.  
 Printed In The U.S.A. Form # 7.02.IN1.B Rev. (11/06) Supersedes (06/03)

## PRE-INSTALLATION: MATERIAL RECEIVING & INVENTORY

### VISUAL INSPECTION:

Upon material arrival, all panel units and molding/ accessory cartons should be visually inspected to verify that the product is in good condition and free from shipping damage, weather damage or defects.

- IS THE PRODUCT IN GOOD CONDITION?
- IS THE PRODUCT FREE FROM DEFECTS?
- IS THE PRODUCT CLEAN AND DRY?

<b>NOTE:</b>
<ul style="list-style-type: none"> <li>Shipping damage and/or packaging issues should be first noted on the bill of lading and then reported to the distributor.</li> <li>Should damage occur, the customer is responsible for filing a freight claim with the shipping company <b>WITHIN 24 HOURS</b> from material receipt. Failure to do so may possibly result in forfeit of corrective action.</li> <li>Any defective material should be reported directly to the distributor from which the product was purchased.</li> </ul>

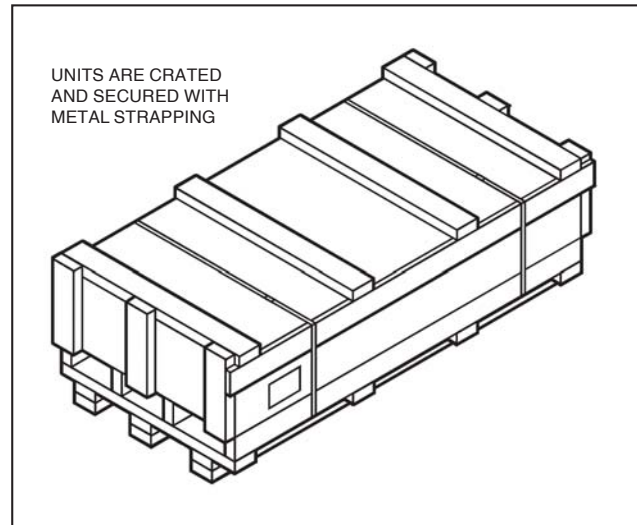
### MATERIAL INVENTORY:

After verifying the condition of the product, inventory units against the packing slip to make sure that all material (including molding and accessory units) is received.

- ARE ALL OF THE PANEL UNITS PRESENT?
- ...THE MOLDING & ACCESSORY UNITS?
- IS THE PIECE PER UNIT COUNT CORRECT?

<b>NOTE:</b>
<p>Notify the distributor from which the product was purchased of any missing or incomplete shipments <b>IMMEDIATELY</b>. Failure to do so may result in forfeit of corrective action.</p>

**FIGURE A.**



## PRE-INSTALLATION: TRANSPORTING & HANDLING

### TRANSPORTING THE MATERIAL:

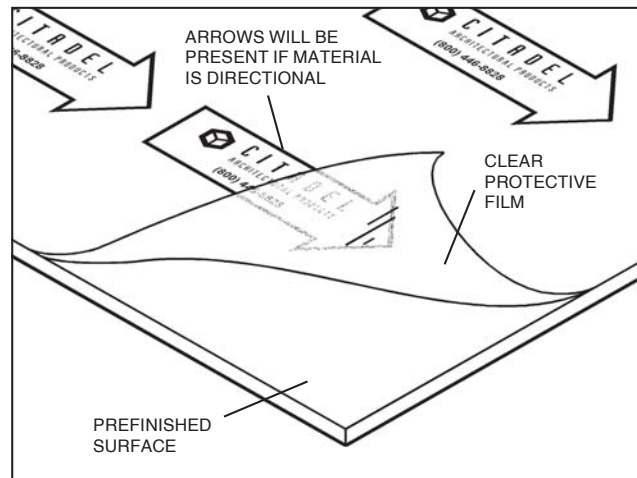
SinoCore® is packaged from the manufacturer in quantities of 40 pieces (or less) per unit, under cover and secured with metal strapping (**FIG. A**). If possible, panels should remain in this original packing for transport.

If a forklift or pallet jack is unavailable, panel unit may be broken and carried to storage by hand according to the following guidelines.

### HANDLING THE MATERIAL:

A strippable protective film (or interleaved foam) is standard on all panels. This film should remain on the product until instructed to take it off (during installation procedure). This strippable film (**FIG. B**) is designed to prevent minor abrasions to the surface. However, panels should still be handled with care to avoid any major dings, dents or scratches.

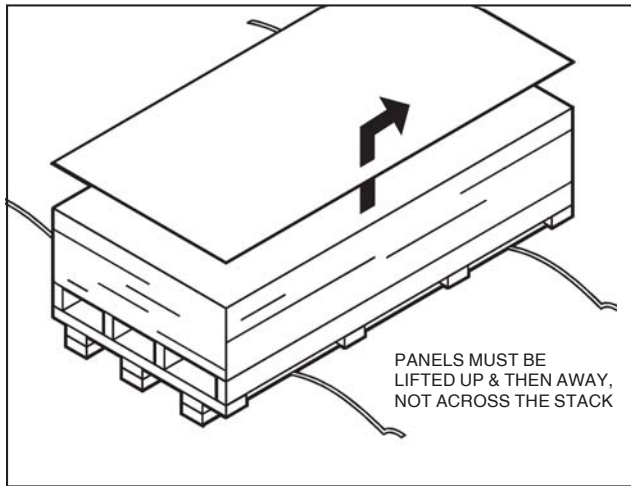
**FIGURE B.**



**NOTE:**

- When handling panels, clean work gloves should be worn at all times to protect from sharp edges and to prevent any smudging of the painted finish.
- When removing material from shipping units, **DO NOT** drag/slide panels across stack underneath. Panels must be lifted up, then away to avoid any permanent damage to the painted surface (FIG. C).

FIGURE C.



**PRE-INSTALLATION:  
STORING THE MATERIAL UNITS**

**MATERIAL STORAGE:**

If the units have been broken, material should be restacked, on a skid. Painted surfaces (strippable film side) should be placed face to face and any interleaved foam must be repositioned.

**NOTE:**

Failure to properly protect material from moisture intrusion may cause damage to the panel surface and/or core. Such damage is NOT covered under the standard warranty.

If the material has become damp or wet during transportation, the surface should be wiped dry before stacking to prevent any type of corrosion. Once the stacking is completed (or if the original packaging is still intact), the units must be covered with a waterproof covering.

All units must be kept in a dry, well-ventilated area away from exposure to the elements and/or any other construction installations which may cause damage to the product.

**PRE-INSTALLATION:  
SCHEDULING & GRID LAYOUT**

**COORDINATION OF WORK:**

In accordance with good construction practice, schedule the work to coordinate with other trades so that installation can proceed without significant interference/delay.

**NOTE:**

Once begun, work should not be delayed for long periods of time at a point which might cause damage to the product if acted upon by external conditions (i.e. rain, snow, long periods of exposure to the sun).

**DETERMINING THE GRID:**

Before beginning the installation procedure, it is important to plan the overall layout of the installation. Architectural drawings should be consulted to determine the correct grid, where applicable.

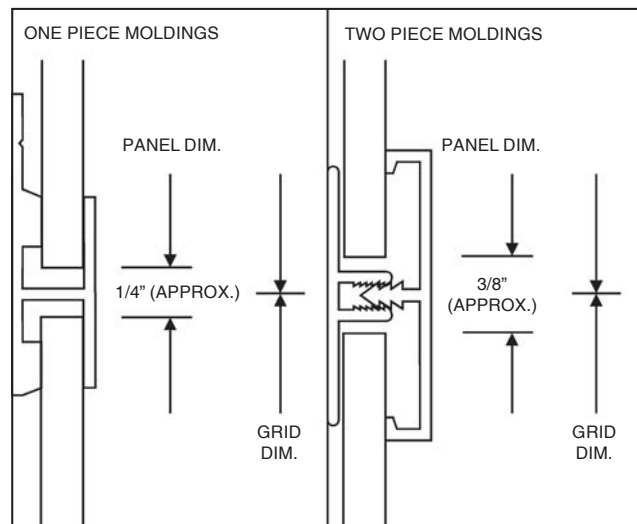
If there are no drawings to work from, measure and verify all field dimensions and develop a pattern to maximize appearance and minimize fabrication. Consideration for aesthetics should be made in locating odd sized panels.

**NOTE:**

**DO NOT** use butting panels as a guide for grid layout. Actual panel size will vary slightly from grid size (FIG. D) due to the spacing needed for panel expansion (1/16") and the molding/receiver width.

For example, a 4' x 10' o.c. grid pattern will result in an actual panel size of slightly less than a full 4' x 10'.

FIGURE D.



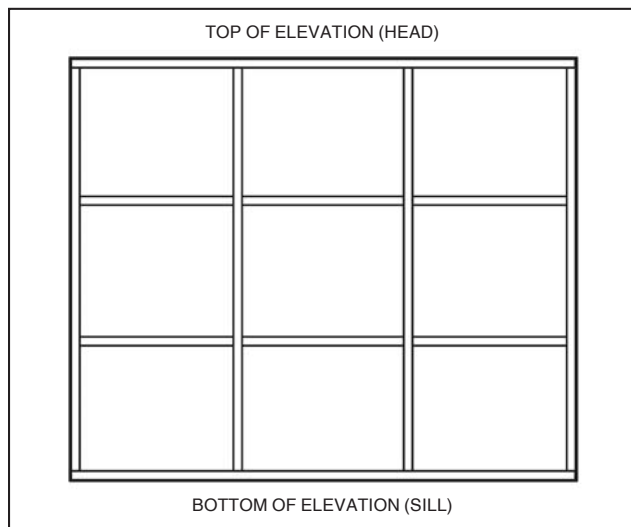
**CALCULATING MATERIAL USAGE:**

After identifying/determining the grid, begin to verify that the correct amount of material has been ordered for your specific application. Since material takeoffs and resulting quantities are based upon the grid layout, installing the material in another pattern may result in shortages.

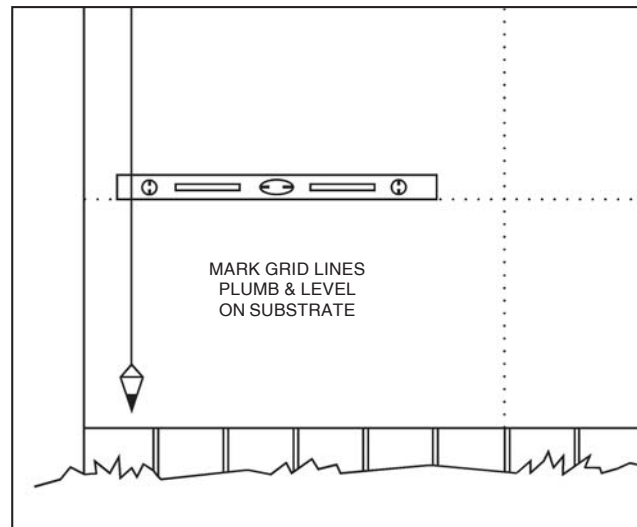
Likewise, an approximate cut plan (for both panels and moldings) should be determined before beginning installation to prevent such shortages which may cause delays in completion of the project.

When calculating molding usage, verticals typically pass through horizontals (**FIG. E**), except at head and sill locations (*see Typical Details*). If the project is large enough to require several lengths of moldings, splices should be staggered so that they do not match up with horizontal/vertical molding intersections (*see General Work: Cutting & Fitting Extrusions*).

**FIGURE E.**



**FIGURE F.**



**ALIGNING & MARKING THE GRID:**

Using the grid pattern derived, establish a base point in the lowermost left corner of the elevation (typically). Using a chalk line, level, and a plumb bob, mark the complete grid (**FIG. F**) on the substrate. Doing so will allow for any necessary adjustment to be made prior to installation.

Installation may also be started at the center line of the elevation and worked in both directions from that point.

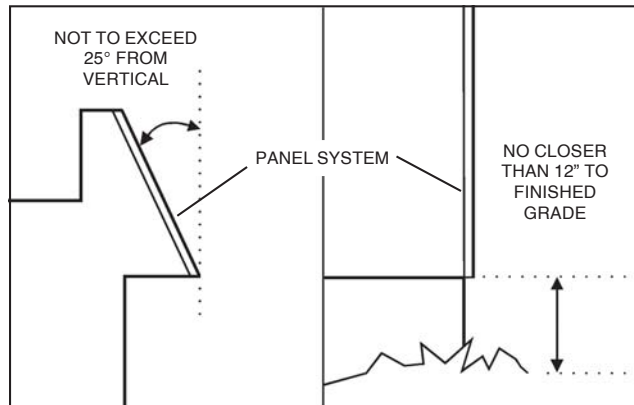
All surfaces of the substrate should be free from any obstructions and/or projections which might interfere with panel application. Note areas where shims may be required to bring the panel system into a plumb, level, and consistent plane.

## GENERAL WORK: LIMITATIONS OF THE PANEL SYSTEM

### USES & APPLICATIONS:

SinoCore® is intended for use as a non-structural wall panel. It may also be used in other applications where the slope does not exceed 25° (FIG. G) past vertical.

FIGURE G.



Also, the system must be kept a minimum of 12" away from the finished landscaping grade. Other environmental and application limitations may apply. Refer to the *Product Warranty*.

## GENERAL WORK: FABRICATION OF THE PANELS

### SAFETY PRECAUTIONS:

When performing fabricating procedures, it is necessary to observe all general guidelines for safety. Cutting, drilling, or otherwise machining the panels and trim moldings may produce flying chips, shavings, or dust.

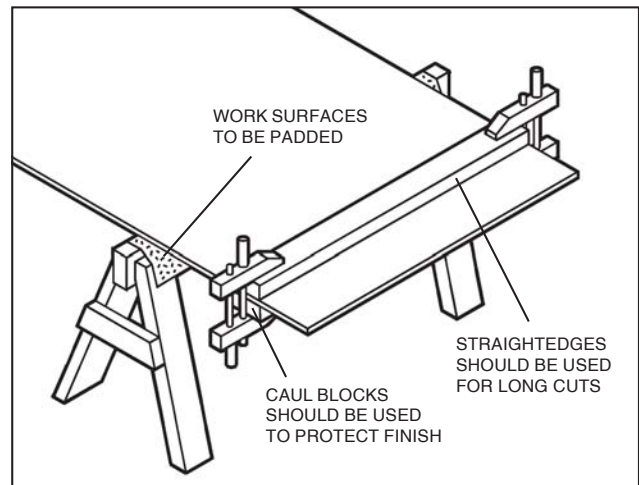
#### NOTE:

In addition to work gloves and proper clothing, safety goggles, ear protection, and possibly dust masks may be needed when fabricating system components.

### CUTTING & DRILLING OF PANELS:

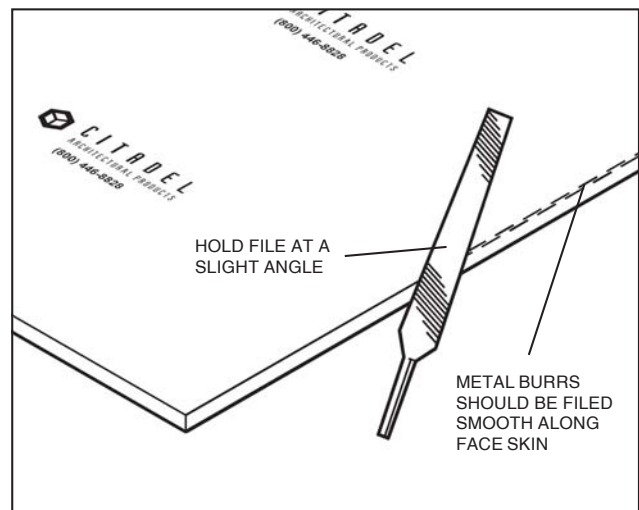
Cut-to-size panels are available from the manufacturer. When field cutting is required, it may be performed using standard carpentry tools equipped with carbide-tipped blades. Work surfaces should be padded (FIG. H) and free from any debris which may damage the finish. For cleaner cuts, backer blocks and straightedges

FIGURE H.



may be clamped to the panel surface. Caul blocks should be used when necessary to protect the painted finish. After cutting, aluminum edges may need filing to remove sharp projections and/or metal burrs (FIG. I) that might prevent the panel from sliding into the molding channel properly. Doing so will also reduce the risk of personal injury.

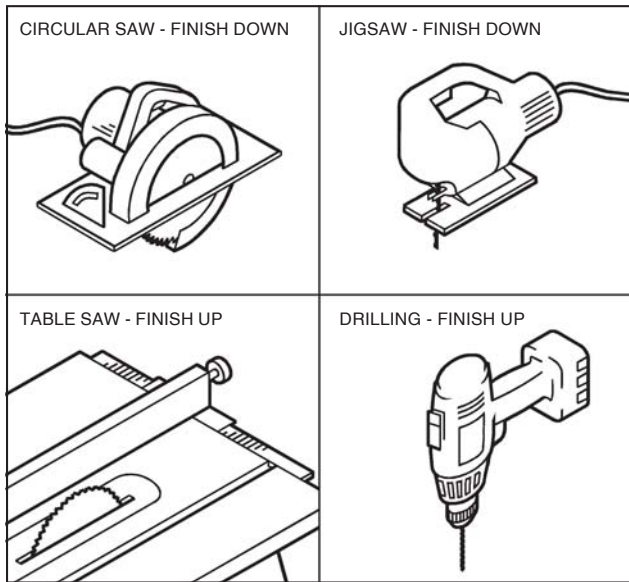
FIGURE I.



When using a table saw to cut panels, the finished side (protective film) should be placed facing upward. For hand held circular saws and jigsaws, the finish side should be facing down (FIG. J). If working with custom color panels and a protective film is not present, the interleaved foam should be placed in a position to protect the painted finish.

For drilling operations, the finished side should be placed facing upward and a backer block should be used when necessary to minimize any tearout.

**FIGURE J.**



**GENERAL WORK:  
CUTTING & FITTING MOLDINGS**

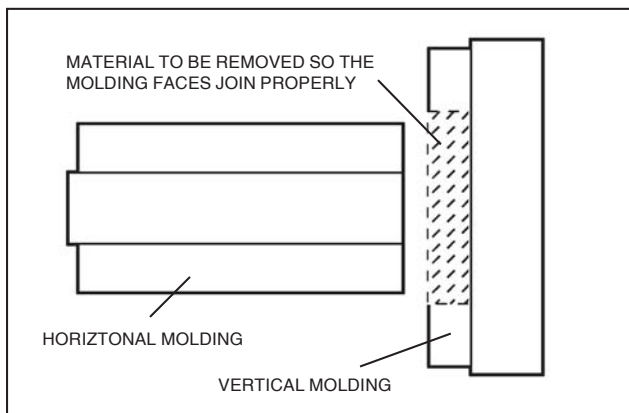
The appearance, quality and soundness of the panel system depends in large part upon the quality and fit of the trim moldings.

For accurate cutting, a miter or chop saw (with carbide tipped blade) is recommended to cut the moldings to length. Notching of moldings may also be required for some intersections. Metal snips and/or a miter saw may be used to remove portions of the moldings so that the intersection can fit together properly (FIG. K).

**NOTE:**

**Whenever cutting, trimming, or installing moldings, it is important to make sure the joints are well fitted and the intersections formed provide a clean channel into which the panel can be placed.**

**FIGURE K.**



A visual representation of the most common intersections can be found in the *Typical Details* section of the *Product Manual*. If you have any questions about how your particular intersection should be fitted, contact our technical staff for assistance.

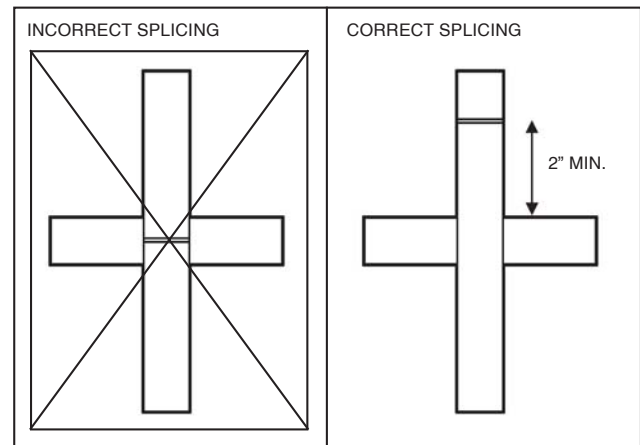
**SPLICING OF MOLDINGS:**

Depending on the grid size, several lengths of moldings may be required to complete a horizontal and/or vertical run. Planning should be done to minimize the number of splices required.

**NOTE:**

**When necessary, splices must occur no closer than 2" away from a horizontal/vertical intersection (FIG. L). Splices must be completely sealed against moisture.**

**FIGURE L.**



**GENERAL WORK:  
PROPER SEALANT APPLICATION**

As a barrier system, SinoCore® is an exterior cladding system designed to keep water away from the structural wall system. Therefore, it is imperative that the following guidelines be followed accurately to ensure the integrity of the system against moisture intrusion.

**NOTE:**

**Failure to adequately seal ALL panel edges, molding intersections & splices, cutouts, etc., will cause the installation to fail and will VOID THE WARRANTY.**

**SELECTING THE RIGHT SEALANT:**

In order for the proper bond to be created between the sealant and the system components, be sure to use only the sealant recommended by the manufacturer.

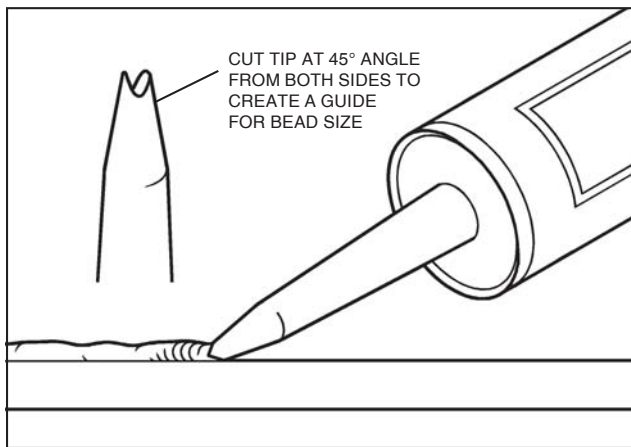
The use of other sealants may require additional steps (such as priming of materials) or cause the installation to fail due to poor weatherability, staining and/or lack of adequate bonding.

**SEALANT APPLICATION:**

In general, sealant should be liberally applied wherever water may be able to infiltrate the system (e.g. joints, molding splices, dissimilar material abutments, etc.).

To aid in applying the proper amount of sealant, the tip of the sealant tube should be cut at an angle from both sides (FIG. M). Doing so will allow the tip to act as a guide (and prevent the sealant from getting spread too thin) when applying the bead.

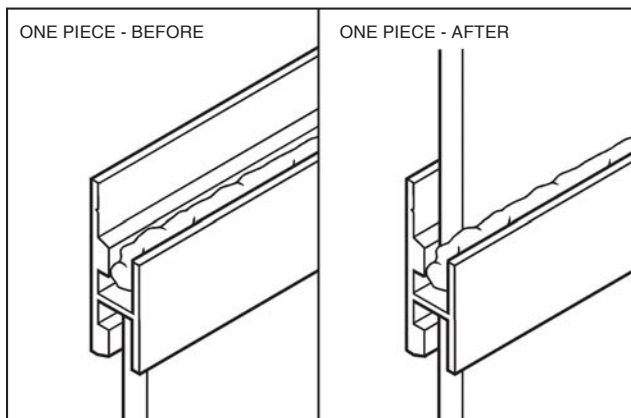
**FIGURE M.**



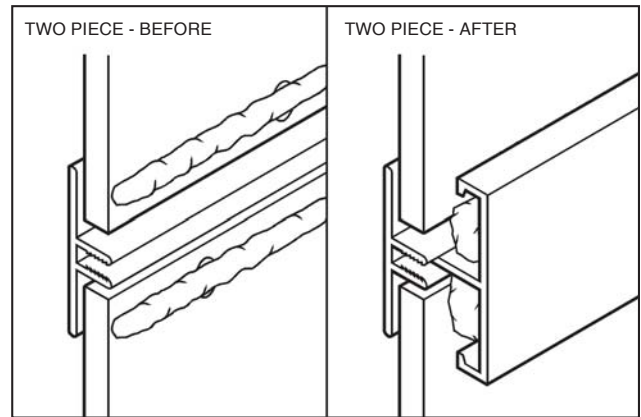
Depending on the system, the amount of material required to adequately seal the panel may vary slightly. However, squeeze out will always occur if the correct amount of sealant has been applied (FIG. N & O).

For one piece systems, the sealant should fill enough of the molding channel (FIG. N) so that squeeze out will occur when the panel is inserted. For two piece systems, a continuous bead (a minimum of 1/4" x 1/4") should be placed along the panel edge before snapping the aluminum cover into place (FIG. O).

**FIGURE N.**

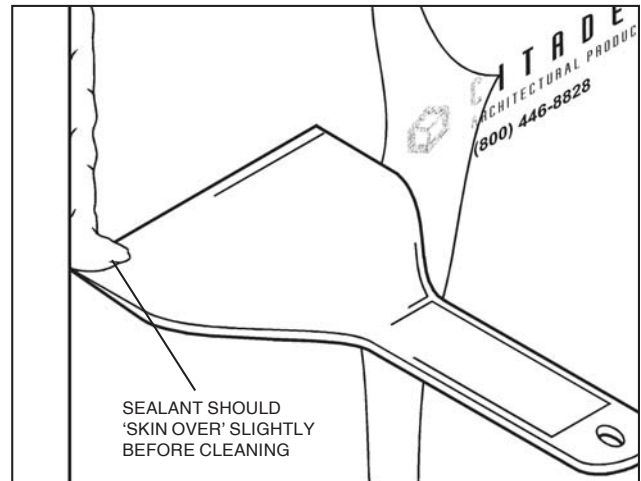


**FIGURE O.**



Excess sealant may be cleaned up (FIG. P) after it 'skins over' (approx. 45 minutes) using a non-marring scraper, a clean rag, and mineral spirits (if necessary).

**FIGURE P.**

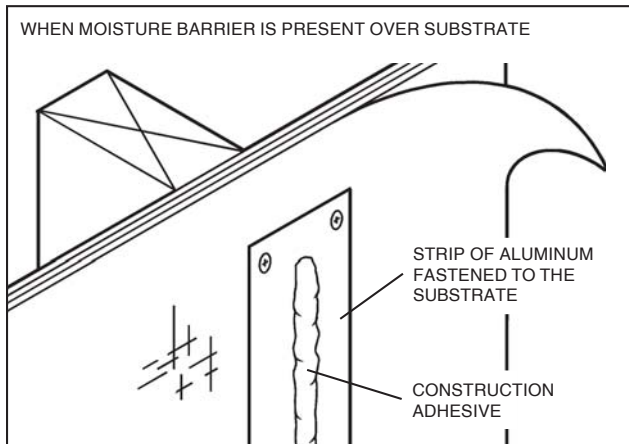


When abutting dissimilar material (i.e. glazing, brick, etc.), allowances must be made for expansion/contraction (minimum 1/4"). Bond breaker tape should be applied to the sheathing prior to the application of the receiver and an approved sealant applied after the panel and aluminum cover are installed (see Typical Details).

**GENERAL WORK:  
PROPER ADHESIVE APPLICATION**

Depending upon the fastening schedule and/or panel size, an adhesive may be required in the field of the panel. Either double-sided tape or construction adhesive may be used to adhere the panel to the substrate. In general, a bead (or strip) of adhesive must be placed at each intermediate location within the field of the panel (16"-24"o.c.). The approximate size of the bead should be 3/8" (min.) x 2/3 of the panel height. When a moisture barrier is present, a strip of aluminum (approx. 2"-3" wide x 2/3 panel height) must be fastened to the substrate (FIG. Q). The adhesive is then applied to the aluminum.

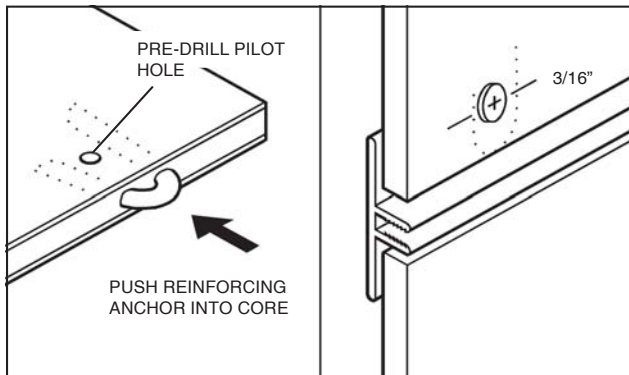
FIGURE Q.



**GENERAL WORK:  
FASTENING THE PANELS & MOLDINGS**

For the one piece molding system, panels are attached to the substrate using construction adhesive and are held in place by the perimeter molding. The moldings are fastened every 12" along its length.

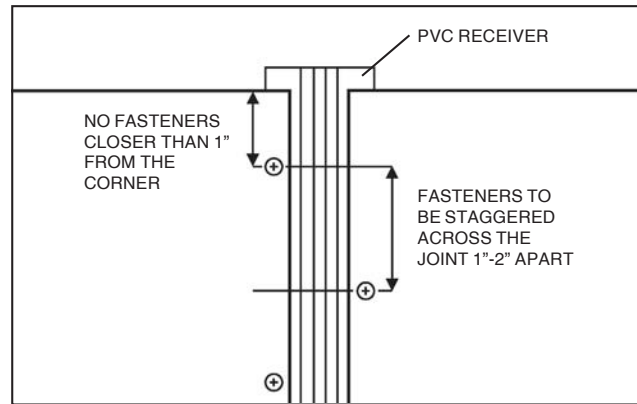
FIGURE R.



The two piece molding system is applied using pvc receivers and aluminum extrusions that are 'snapped' into place after the panel is installed. A reinforcing anchor is placed in the core of the panel to prevent fasteners from dimpling the face skin. A pilot hole is then drilled at the anchor location. Panel fasteners are placed 12"-16" around the perimeter 3/16" from the panel edge (FIG. R) and adhesive is applied in the field at 24" o.c. minimum. Perimeter fasteners should be staggered 1"-2" (FIG. S) across the joint for two adjoining panels. Fasteners should not be placed within 1" of the corner as panel tearout may occur.

**NOTE:**  
**ALL panel fasteners must be driven snug to the panel. DO NOT countersink (or overdrive) the fastener head past the aluminum skin.**

FIGURE S.



**GENERAL WORK:  
THE PROTECTIVE FILM**

When directed to do so (see Work Sequence), the protective film must be removed from the panel surface. For ease of removal, pull the film back against itself in the same plane as the panel.

**NOTE:**  
**Failure to remove the protective film promptly after installation (or exposure to long periods of sunlight) may cause difficulties in removal and possibly leave an adhesive residue.**

**MAINTENANCE OF THE  
PANEL FINISH**

**REPAIR/TOUCH UP:**

Any minor scratches or dings which may occur during installation can be repaired using touch-up paint available from the manufacturer. Repainting of large areas with the touch-up paint is not recommended. Finish characteristics of the repainted surface may vary from the pre-painted aluminum.

**MAINTENANCE:**

Panels should be incorporated into an overall building washing/maintenance schedule and cleaned in accordance with AAMA 610.1, Voluntary Guide Specification for Cleaning and Maintenance of Painted Aluminum Extrusions and Curtain Wall Panels.

In general, panels may be cleaned using warm water and a mild detergent (if necessary). For more aggressive materials, a gentle brushing/scrubbing action may be required. Abrasive detergents and/or harsh solvents should not be used.



## WORK SEQUENCE: ONE PIECE EXTRUDED MOLDINGS



STOP! READ BEFORE PROCEEDING WITH WORK SEQUENCE



These guidelines are set forth to show the intent and general sequence of installation. The procedure for each individual application and condition may vary. For special conditions or for those not discussed (parapet, dissimilar material, etc.), refer to the General Work Guidelines, Typical Details or contact the manufacturer.

### INSTALLATION SPECIFICATIONS:

#### System Type:

- Non-Structural, Barrier System

#### Work Flow:

- Progressive, moving up and across the elevation beginning at a bottom corner (typical).

#### Possible Substrates:

- Nailable Substrate
- Non-Nailable Substrate (fastened directly to studs)
- Substrate (either type) with Moisture Barrier (special instructions apply)
- Furring Strips on Masonry (16"-24" o.c.)

#### Expansion/Contraction Spacing:

- 1/16" between panel perimeter edge and molding

#### Types Of Fasteners:

- Metal Framing: #S-1000 (1") or #S-1580 (1-5/8")
- Wood Framing & Sheathing: #S-1001 (1-5/8")

#### Fastening Schedules:

- Panel Fastening (non-mechanical):  
Panels are attached to the substrate using construction adhesive and are held in place by the perimeter molding.
- Molding Fastening:  
Every 12" along length of molding

#### Adhesive:

- #5000 (Franklin Titebond™)
- #5003-D (Double Sided Tape)  
A bead (or strip) approx. 2/3 the panel height is placed at intermediate (16"-24" o.c.) locations.

#### Sealant:

- #5002 (Tremco® Spectrem® 2)  
The entire system must be properly sealed against moisture for the warranty to remain valid.

### □ STEP 1: ATTACHING THE BOTTOM HORIZONTAL & THE LEFT VERTICAL MOLDINGS

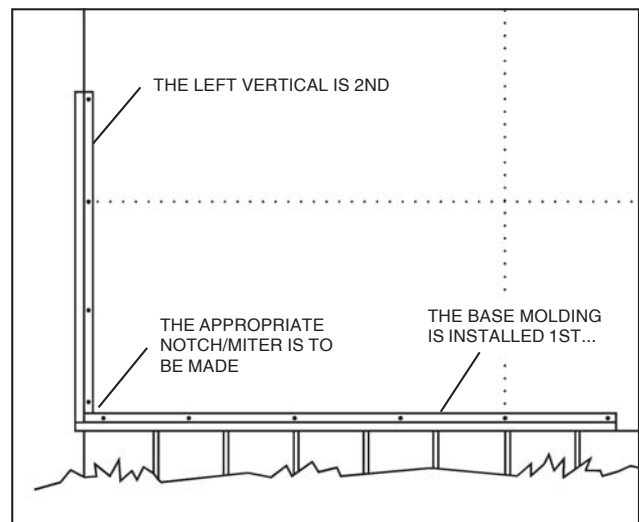
Since the installation is progressive, the panel is encapsulated on all four sides by the one piece moldings. Therefore, the first step in the work sequence is creating an 'L' shaped pocket into which the panel will be placed.

In order to move the installation up, and then across the elevation, the first two moldings to be attached are the bottom horizontal and the left vertical (**FIG. 1**).

Miter or notch the moldings as needed and then fasten them to the substrate. Keep in mind that verticals 'pass through' horizontals except at head and sill locations.

The required molding length will vary dependent upon condition and grid layout.

FIGURE 1.



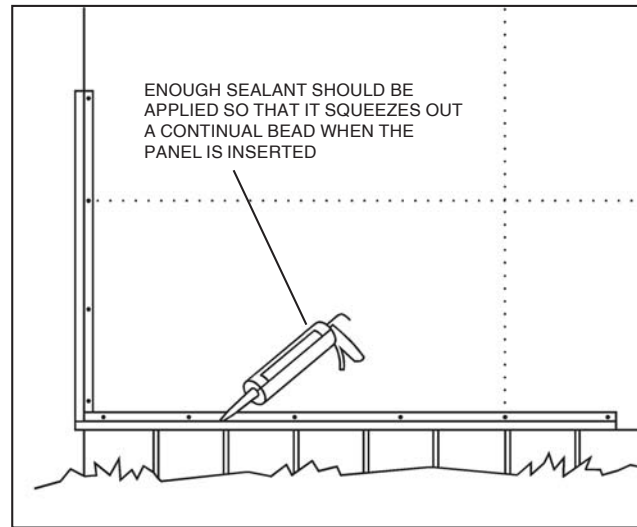
**□ STEP 2: PREPARING THE PANEL & APPLYING THE SEALANT**

Begin by cutting the panel to the proper dimension with allowance made for expansion/contraction. Peel the protective film away from all four edges of the panel. Do not remove it completely.

<b>NOTE:</b>
<b>Failure to adequately seal ALL panel edges will cause the installation to fail and will VOID THE WARRANTY.</b>

Place a large, continuous bead of approved sealant into both the bottom horizontal and left vertical moldings (**FIG. 2**). If the moldings extend past the first panel length/width, apply only enough sealant for one panel.

**FIGURE 2.**

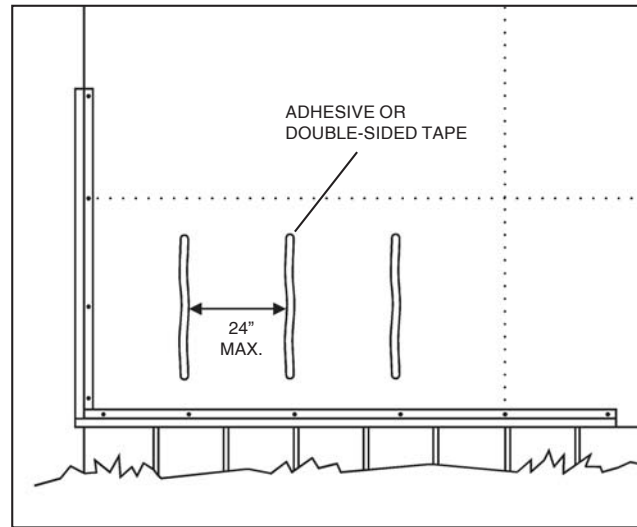


**□ STEP 3: APPLYING THE PANEL ADHESIVE**

Place a large bead (or strip if using double-sided tape) of panel adhesive onto the substrate at each intermediate location (**FIG. 3**).

<b>NOTE:</b>
<b>The adhesive bead should not be allowed to set up before the panel is applied.</b>

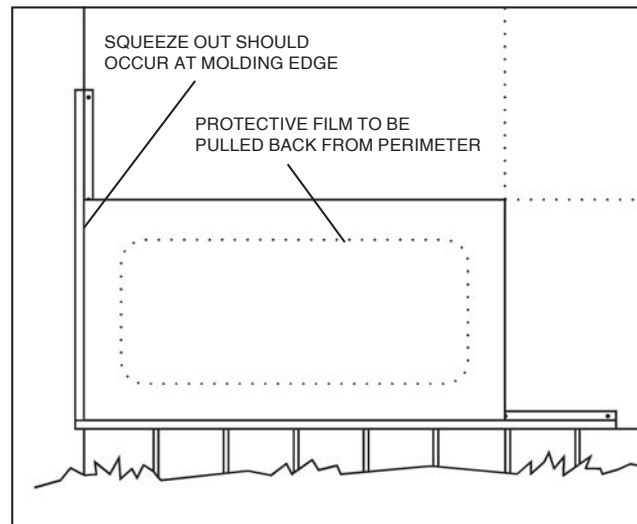
**FIGURE 3.**



**□ STEP 4: INSERTING THE PANEL INTO THE MOLDING CHANNELS**

Insert the panel into the moldings (a non-marring scraper may assist in guiding the panel into the channel). If the correct amount of sealant is applied, it should squeeze (**FIG. 4**) from the molding in a continual bead around the panel perimeter. The excess will be removed in a later step.

**FIGURE 4.**



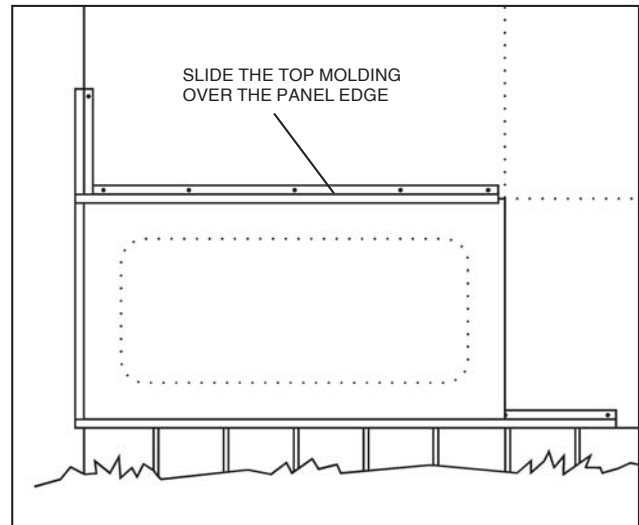
### □ STEP 5: ATTACHING THE TOP HORIZONTAL MOLDING

Since verticals typically dominate, the top horizontal molding should be notched/mitered to 'dive into' the left vertical molding. Likewise the other end of the molding should be notched/mitered after being cut to length to receive the right vertical molding to be attached next.

After the molding has been prepared, apply the proper amount of sealant into the channel (only the side facing the panel) and place it over the edge (**FIG. 5**). As in the previous step, sealant squeeze out should occur.

Fasten the top molding to the substrate.

**FIGURE 5.**



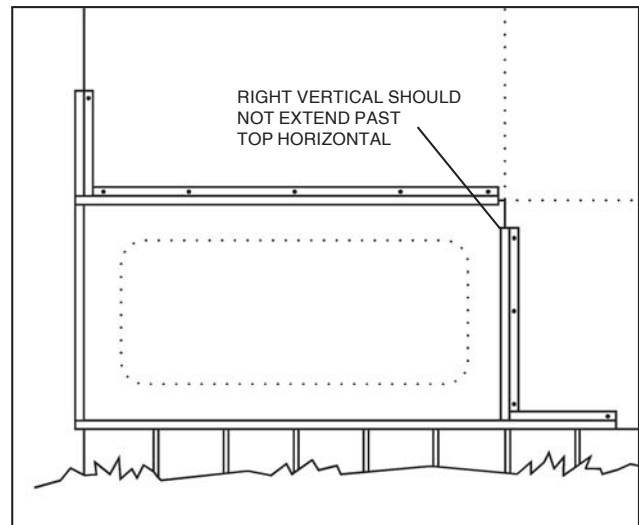
### □ STEP 6: ATTACHING THE RIGHT VERTICAL MOLDING

After preparing (cutting, applying sealant), the right vertical should be fastened to the substrate (**FIG. 6**).

**NOTE:**

The final molding in the sequence (the right vertical) should never extend past the top horizontal (**FIG. 6**). Doing so will create a 'U' shaped channel and prevent the next panel in the vertical sequence from being installed properly.

**FIGURE 6.**



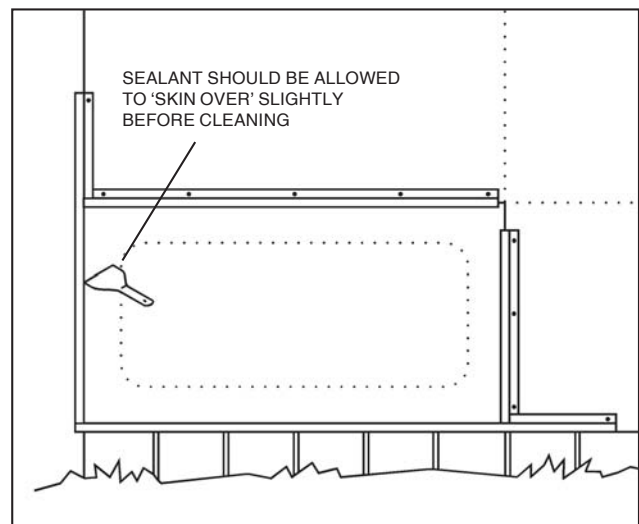
### □ STEP 7: CLEANING UP THE EXCESS SEALANT AND REMOVING THE PROTECTIVE FILM

Once the fastening is complete, the excess sealant can be cleaned from the panel surface using a non-marring scraper, clean rag, and mineral spirits (if necessary).

The scraper should be held at a low angle (**FIG. 7**) and run along the perimeter of the panel using the molding as a guide.

Once completed, remove the protective film by pulling it back against itself along the panel.

**FIGURE 7.**

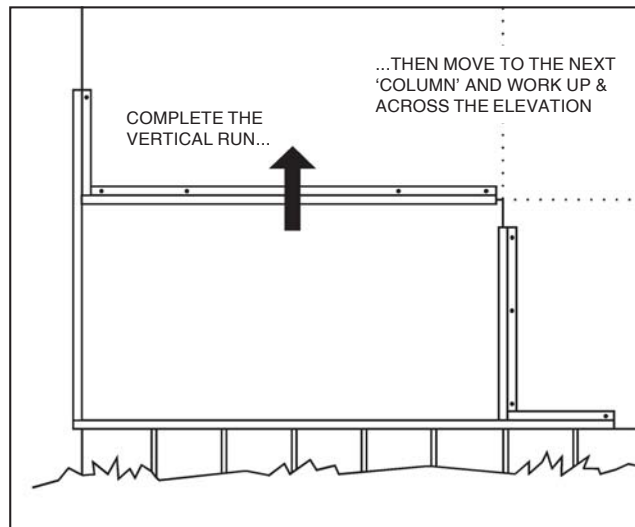


**□ STEP 8: MOVING UP AND ACROSS THE ELEVATION**

Once the first panel is installed, repeat the work sequence and move vertically in the grid. Upon completion of the first column, move again to the bottom of the elevation and begin at the next column.

Each individual application may vary depending upon layout. However, moving vertically across the elevation requires the least amount of setup and may prove the most efficient use of scaffolding and/or power lifts.

**FIGURE 8.**



## WORK SEQUENCE: TWO PIECE EXTRUDED MOLDINGS



STOP! READ BEFORE PROCEEDING WITH WORK SEQUENCE



These guidelines are set forth to show the intent and general sequence of installation. The procedure for each individual application and condition may vary. For special conditions or for those not discussed (parapet, dissimilar material, etc.), refer to the General Work Guidelines, Typical Details or contact the manufacturer.

### INSTALLATION SPECIFICATIONS:

#### System Type:

- Non-Structural, Barrier System

#### Work Flow:

- Non-Progressive, moving up and across the elevation beginning at a bottom corner (typical).

#### Possible Substrates:

- Nailable Substrate
- Non-Nailable Substrate (fastened directly to studs)
- Substrate (either type) with Moisture Barrier (special instructions apply)
- Furring Strips on Masonry (16"-24" o.c.)

#### Expansion/Contraction Spacing:

- 1/16" between panel perimeter edge and receiver

#### Types Of Fasteners:

- Metal Framing: #S-1000 (1") or #S-1580 (1-5/8")
- Wood Framing & Sheathing: #S-1001 (1-5/8")

#### Fastening Schedules:

- Panel Fastening:  
12"-16" around panel perimeter—located 3/16" away from edge, driven snug to the panel through the reinforcing anchor, not countersunk (no fasteners within 1" of corner)
- Receiver Fastening (temporary):  
Every 24"-36" along length, using brads/staples

#### Adhesive:

- #5000 (Franklin Titebond™)
- #5003-D (Double Sided Tape)  
A bead (or strip) approx. 2/3 the panel height is placed at intermediate (16"-24" o.c.) locations.

#### Sealant:

- #5002 (Tremco® Spectrem® 2)  
The entire system must be properly sealed against moisture for the warranty to remain valid.

### □ STEP 1: ATTACHING THE PLASTIC RECEIVERS TO THE SUBSTRATE

Being a non-progressive system, the panels are set upon plastic receivers and the edge is encapsulated by an aluminum cover molding.

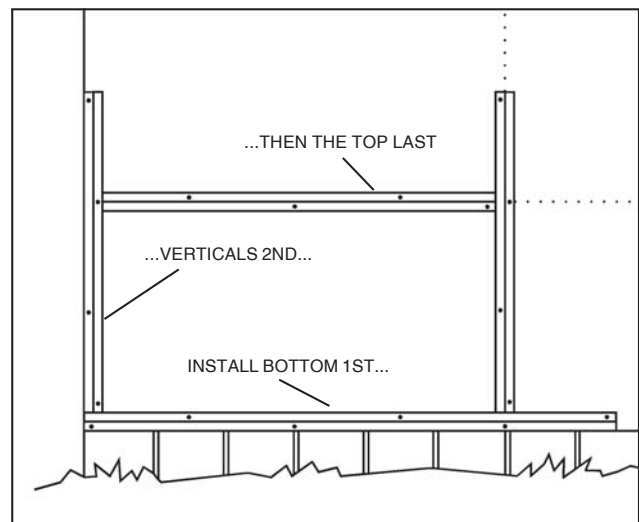
First, attach the bottom horizontal receiver to the substrate using a small brad or staple. Next, attach the left vertical (verticals dominate except at head and sill locations) followed by the right vertical.

Then measure, cut, and attach the top horizontal.

#### NOTE:

Do not install receivers for more than 3-4 panels at a time. Long exposure to sun may cause misalignment.

FIGURE 1.



**□ STEP 2: PREPARING THE PANEL AND APPLYING THE ADHESIVE**

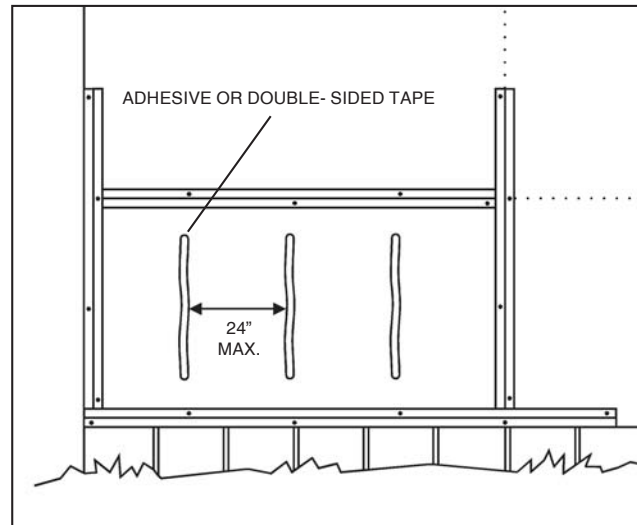
Begin by cutting the panel to the proper dimension with allowance made for expansion/contraction.

Next, mark the locations of the perimeter fasteners and insert the reinforcing anchor into the core. Then, drill the pilot hole through the panel and anchor at each location.

Peel the protective film away from all four edges of the panel. Do not remove it completely.

Finally, place a large bead (or strip if using double-sided tape) of panel adhesive onto the substrate at each intermediate location (**FIG. 2**).

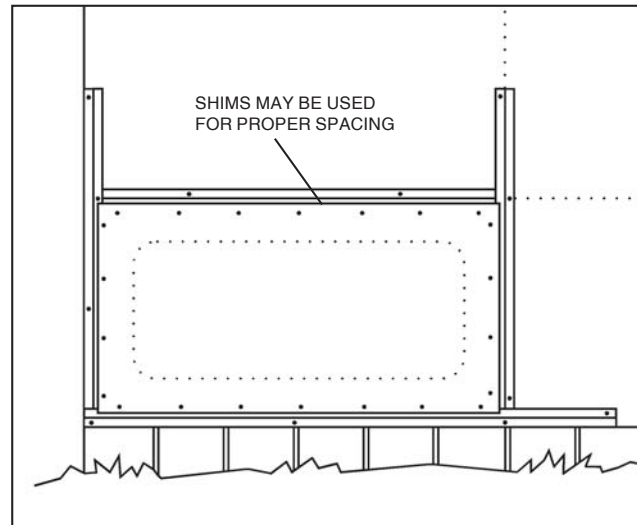
**FIGURE 2.**



**□ STEP 3: ATTACHING THE PANEL TO THE SUBSTRATE**

Place the panel onto the receivers (a shim may be helpful in maintaining the proper spacing (**FIG. 3**) around the perimeter) and fasten it to the substrate.

**FIGURE 3.**



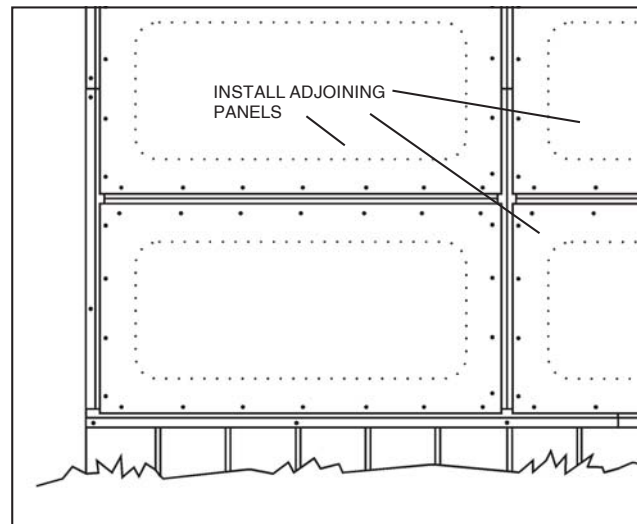
<b>NOTE:</b>
<ul style="list-style-type: none"> <li>• The adhesive bead should not be allowed to set up before the panel is applied.</li> <li>• DO NOT overdrive fasteners. Doing so will cause the face of the panel to dimple.</li> </ul>

**□ STEP 4: REPEATING THE PROCESS FOR ADJOINING PANELS**

Because the aluminum covers snap over the edges of two panels (with the exception of the perimeter molding), it is necessary to install one or more adjoining panels before continuing.

Repeat **STEPS 1-3**, installing additional panels in the grid. Remember to align the vertical receivers so that they 'pass through' the horizontals (**FIG. 4**).

**FIGURE 4.**



#### □ STEP 5: CUTTING THE MOLDING & APPLYING THE PERIMETER SEALANT

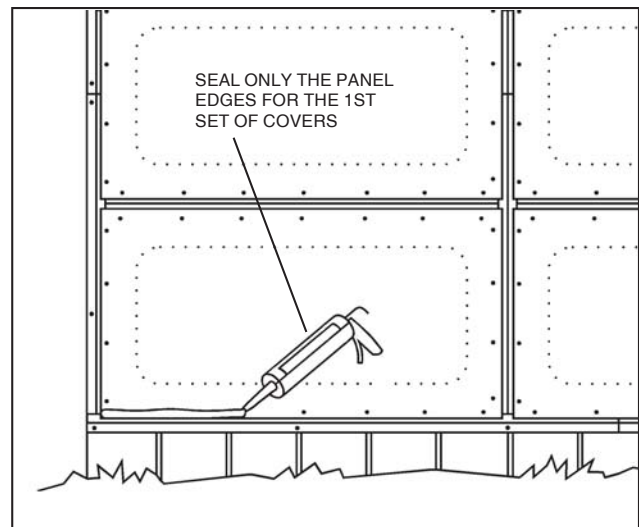
Once the adjoining panels are installed, cut the appropriate cover moldings to length making any necessary miters (if required).

Next, liberally apply a large bead of sealant around the panel perimeter (**FIG. 5**).

#### NOTE:

Apply sealant only to those areas/panels where the cover will be immediately installed.

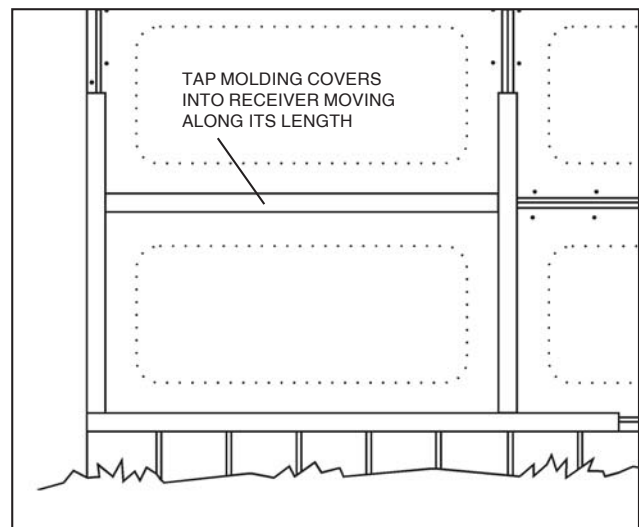
FIGURE 5.



#### □ STEP 6: SNAPPING THE ALUMINUM COVER INTO PLACE

Once the proper amount of sealant has been applied, the cover molding may be 'snapped' into place. Begin at one end and 'tap' the cover molding into place using a rubber mallet, moving along its length (**FIG. 6**). If the proper amount of sealant was applied, a continuous bead should squeeze out from the joint.

FIGURE 6.



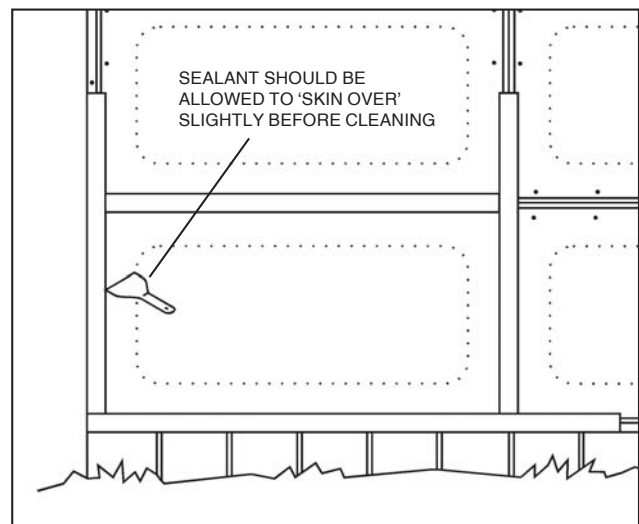
#### □ STEP 7: CLEANING UP THE EXCESS SEALANT AND REMOVING THE PROTECTIVE FILM

Once the aluminum cover is snapped into place, the excess sealant can be cleaned from the panel surface using a non-marring scraper, clean rag, and mineral spirits (if necessary).

The scraper should be held at a low angle (**FIG. 7**) and run along the perimeter of the panel using the molding as a guide.

Once completed, remove the protective film by pulling it back against itself along the panel.

FIGURE 7.

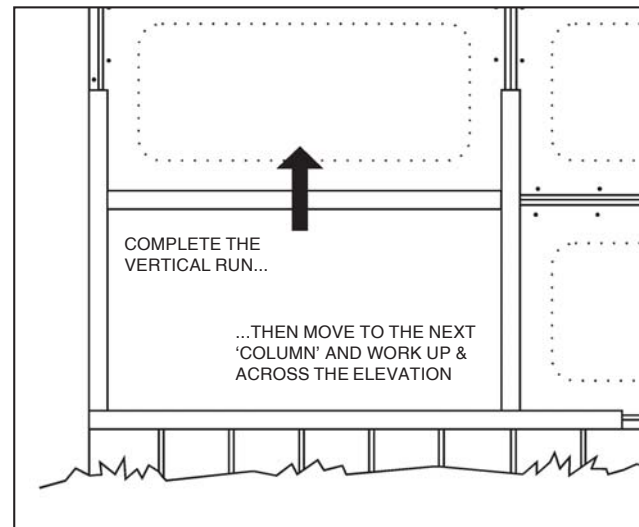


**□ STEP 8: MOVING UP AND ACROSS THE ELEVATION**

Once the first panel is installed, repeat the work sequence and move vertically in the grid. Upon completion of the first column, move again to the bottom of the elevation and begin at the next column.

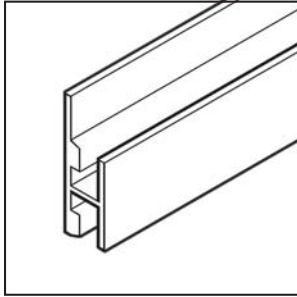
Each individual application may vary depending upon layout. However, moving vertically across the elevation requires the least amount of setup and may prove the most efficient use of scaffolding and/or power lifts.

**FIGURE 8.**

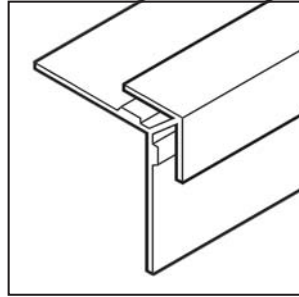




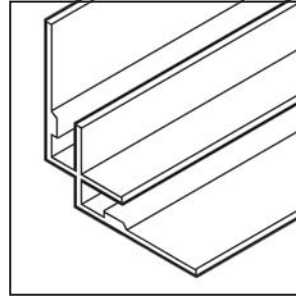
**ONE PIECE EXTRUDED ALUMINUM MOLDINGS**



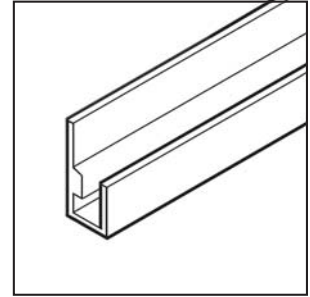
**E-301 HORZ/VERT**  
 Height: 1-1/2" (38mm)  
 Width: 1/2" (13mm)  
 Length: 12' (3658mm)



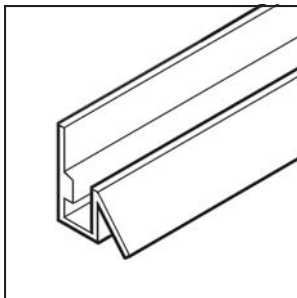
**E-302 O/S CORNER**  
 Face Leg: 3/4" (19mm)  
 Width: 2" (51mm)  
 Length: 12' (3658mm)



**E-303 I/S CORNER**  
 Face Leg: 1/2" (13mm)  
 Height: 1-7/8" (48mm)  
 Length: 12' (3658mm)

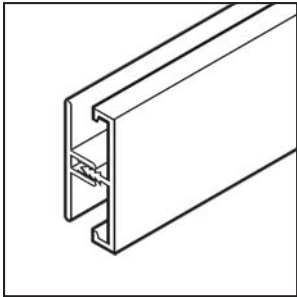


**E-304 PERIMETER J**  
 Face Leg: 1/2" (13mm)  
 Height: 1" (25mm)  
 Length: 12' (3658mm)

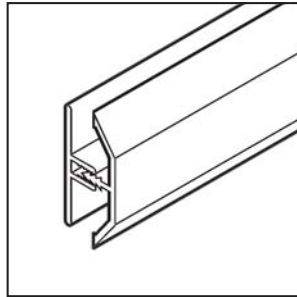


**E-305 DRIP EDGE**  
 Face Leg: 1/2" (13mm)  
 Height: 1" (25mm)  
 Length: 12' (3658mm)

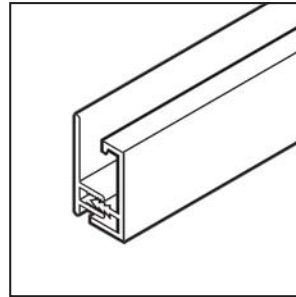
**TWO PIECE EXTRUDED ALUMINUM MOLDINGS**



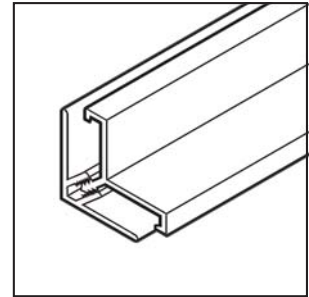
**C20-401 HORZ/VERT**  
 Height: 1-1/2" (38mm)  
 Length: 12' (3658mm)  
 SC-8240 PVC RECEIVER: 12'



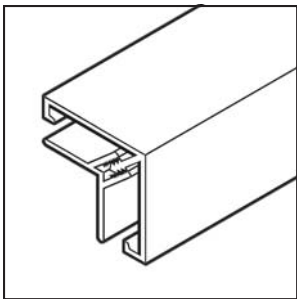
**C20-402 HORZ/VERT**  
 Height: 1-1/2" (38mm)  
 Length: 12' (3658mm)  
 R20-401 PVC RECEIVER: 12'



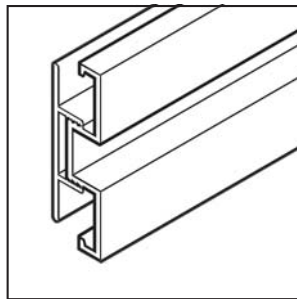
**SC-604 PERIMETER J**  
 Height: 1" (25mm)  
 Length: 12' (3658mm)  
 R20-403 PVC RECEIVER: 12'



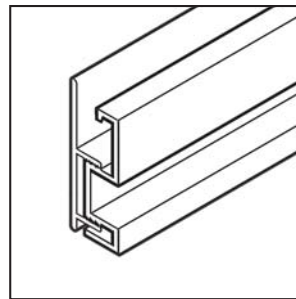
**C20-404 I/S CORNER**  
 I/S Legs: 3/4" (19mm)  
 Length: 12' (3658mm)  
 R20-404 PVC RECEIVER: 12'



**C20-405 O/S CORNER**  
 O/S Legs: 1-1/4" (32mm)  
 Length: 12' (3658mm)  
 R20-405 PVC RECEIVER: 12'



**C20-406 HORZ/VERT**  
 Height: 2" (52mm)  
 Reveal: 1/2" (13mm)  
 Length: 12' (3658mm)  
 R20-406 PVC RECEIVER: 12'



**C20-407 PERIMETER J**  
 Height: 1-1/2" (38mm)  
 Reveal: 1/2" (13mm)  
 Length: 12' (3658mm)  
 R20-407 PVC RECEIVER: 12'





## TOOLING & EQUIPMENT

Recommended Tooling:	
<b>Measuring/Marking:</b> <input type="checkbox"/> Tape Measure (16' minimum) <input type="checkbox"/> Laser/Handheld Level (4' minimum) <input type="checkbox"/> Chalk Line <input type="checkbox"/> Plumb Bob <input type="checkbox"/> T-Square <input type="checkbox"/> Framing Square <b>Hand Tools:</b> <input type="checkbox"/> Framing Hammer (non-marring tip) <input type="checkbox"/> Rubber Mallet	<input type="checkbox"/> Caulking Gun <input type="checkbox"/> Box Knife <input type="checkbox"/> Metal File <input type="checkbox"/> Metal Snips <b>Power Tools:</b> (carbide tipped blades) <input type="checkbox"/> Table Saw <input type="checkbox"/> Circular Saw <input type="checkbox"/> Miter/Chop Saw <input type="checkbox"/> Jigsaw <input type="checkbox"/> Power Drill <input type="checkbox"/> Screw Gun

Recommended Equipment:	
<b>Safety:</b> <input type="checkbox"/> Safety Glasses <input type="checkbox"/> Work Gloves <input type="checkbox"/> Dust Mask <input type="checkbox"/> Hearing Protection <b>Fabrication:</b> <input type="checkbox"/> Sawhorses <input type="checkbox"/> Scrap Sheets Of Plywood (3/4") <input type="checkbox"/> Clamps (with cauls) <input type="checkbox"/> Straightedge <input type="checkbox"/> Plastic/Wood Shims	<b>Jobsite:</b> <input type="checkbox"/> Scaffolding <input type="checkbox"/> Power Lift <input type="checkbox"/> Plastic/Canvas Cover(s) <b>CleanUp:</b> <input type="checkbox"/> Mild Detergent <input type="checkbox"/> Mineral Spirits <input type="checkbox"/> Non-Marring Scraper <input type="checkbox"/> Clean Shop Rags

Note: Depending upon your installation, some items may be optional.

## MECHANICAL FASTENERS

Item #	Description	Application
<b>S-1000 CLIMASEAL SCREW</b> 	Length: 1" (25mm) Pieces Per Box: 500 Weight: 2 lbs.	Fastening the panel to metal framing
<b>S-1580 CLIMASEAL SCREW</b> 	Length: 1-5/8" (41mm) Pieces Per Box: 500 Weight: 2 lbs.	Fastening the panel to metal framing
<b>S-1001 HI-LO SCREW</b> 	Length: 1-5/8" (41mm) Pieces Per Box: 500 Weight: 2 lbs.	Fastening the panel to wood framing
<b>7011-RA SINOCORE® REINFORCING ANCHOR</b> 	Length: 7/8" (22mm) Pieces Per Box: 500 Weight: 2 lbs.	Inserted into core to prevent the screw from dimpling the surface

Small nails or brads (available at a local hardware store) may be used for temporarily attaching the plastic receivers to the substrate.  
 Note: Fasteners shown actual size.

**SEALANTS, ADHESIVES AND TOUCH-UP**

Item #	Description	Application
<b>5000 CONSTRUCTION ADHESIVE</b> Franklin Titebond™	Tube Size: 10.5 oz. (approx. 30 lineal ft. per tube at a 1/4" bead)	Along with mechanical fasteners, the panel is adhered to the substrate/stud framework using construction grade adhesive.
<b>5002 SEALANT</b> Tremco® Spectrem® 2	Tube Size: 11 oz. (approx. 30 lineal ft. per tube at a 1/4" bead)	Proper application of approved sealant is critical to the integrity of the panel system. Failure to do so will void the product warranty.
<b>5003-D DOUBLE SIDED TAPE</b>	1/8" x 1" x 54' roll	As an alternative to construction adhesive, double sided tape may be used in some applications to adhere the panel to the substrate.
<b>PA-46 POLYESTER TOUCH-UP PAINT</b> Kynar 500® may also be available. Contact Inside Sales for pricing.	Container: 7 oz.	During installation, minor scratches, abrasions, and/or dings may occur. If necessary, repairs can be performed using small bottles of color matched paint. Touch-up paint should not be used for painting large areas or trim.